



Hammond
Power Solutions

Instructions for

Receiving, Installing, Operating and Maintaining Air-Core Reactors

| | |
|---|----|
| 1 - SAFETY INDICATIONS | 2 |
| 2 - GENERAL INFORMATION | 3 |
| 3 - RATING PLATE | 4 |
| 3.1 - Check the condition for correct operation of the reactor | 4 |
| 4 - RECEIVING, STORAGE AND TRANSPORT | 5 |
| 4.1 - Inspection and acceptance | 5 |
| 4.2 - Lifting the reactor | 5 |
| 4.3 - Moving the reactor with box (only if wheels provided) | 6 |
| 4.4 - Storage | 6 |
| 5 - INSTALLATION | 7 |
| 5.1 - Installation guide | 7 |
| 5.2 - Connections | 8 |
| 5.3 - Tightening torque for electrical and mechanical connections | 9 |
| 5.4 - Positioning | 9 |
| 5.5 - Ventilation | 10 |
| 5.6 - Dry out | 10 |
| 5.7 - Overvoltages | |
| 6 - COMMISSIONING | 11 |
| 6.1 - Earth Connection | 11 |
| 6.2 - Cleaning | 11 |
| 6.3 - Electrical inspection check list | 11 |
| 6.4 - Mechanical inspection check list | 11 |
| 7 - MAINTENANCE | 12 |
| 7.1 - Suggested maintenance and control activities | 12 |
| 7.2 - Guide for trouble-shooting | 13 |
| 7.3 - Customer Care | 14 |
| 7.4 - Warranty | 14 |

However, the supplier assumes no responsibility for its use or misuse and warns the reader to exercise caution in the installation and maintenance of the products described herein

These instructions do not propose to cover all details or variations in equipment, nor to provide for every contingency to be met in connection with installation, operation, or maintenance. Should further information be desired, or particular problems arise which are not covered, please contact the factory.

PLEASE READ ENTIRE DOCUMENT BEFORE FOLLOWING ANY PART OF IT

1 - SAFETY INDICATIONS



SAFETY PRECAUTIONS



Do not lift or move a reactor without proper equipment and experienced personnel.

Do not off-load the reactor until a full inspection has been completed.

Use terminals only for electrical connections and flexible connectors are recommended.

Connections should only be in accordance with nameplate diagram or connection drawings.

The reactor must be de-energized and all terminals grounded prior to any maintenance

Make certain all connections are complete and tightened before energizing the reactor.

Do not attempt to change any taps, while the reactor is energized.

Do not change connections when the reactor is energized.

Do not tamper with control panels, interlocks or control circuits.

Do not adjust or remove any accessories or cover plates while the reactor is energized

2 - GENERAL INFORMATION

HPS S.p.A. reactors are manufactured to provide optimum performance for lifetime of uninterrupted service.

Careful attention to the following instructions is recommended for safe and reliable operation.

As with any electrical device, reactors must be installed according to the requirements of international IEC code or other codes on request.

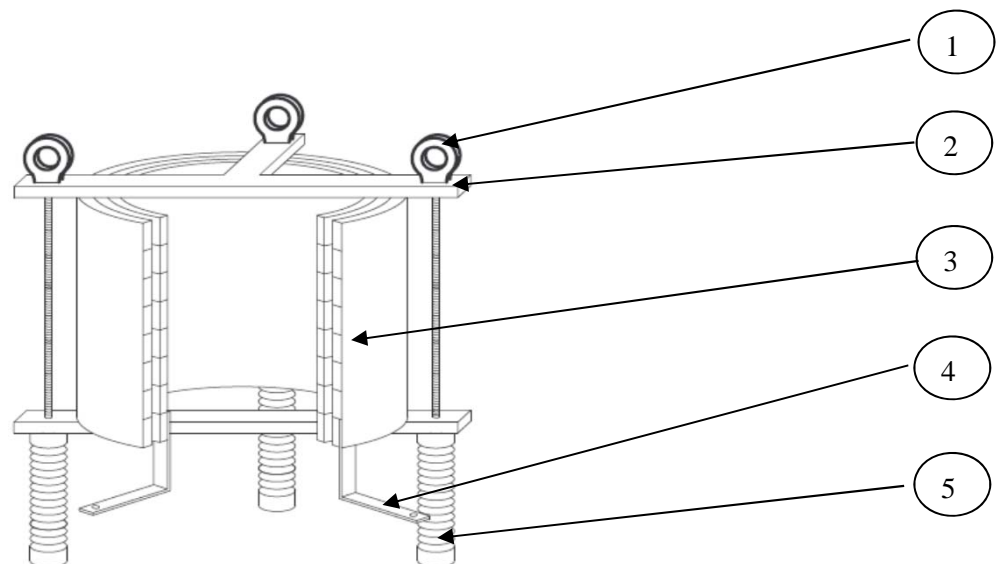
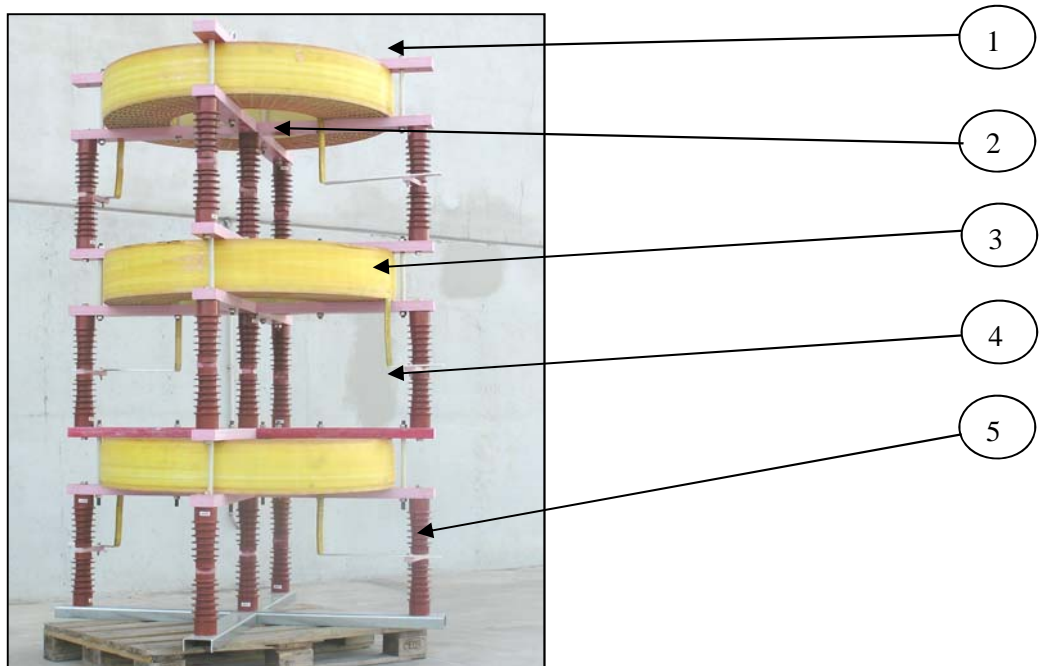

- 1 - Lifting eye bolts
- 2 - Spider member
- 3 - Winding and cooling duct spacers
- 4 - Terminal
- 5 - Station post insulator

3 - RATING PLATE

Every reactors produced by HPS S.p.A. have a label that shows the rating value of the reactor

Two types of label are available:

A - Paper label

| | | | | | | | | | |
|----------------------------|---------------------------------|------------------------|---------------------------------|------------------------|---------------------------------|---------------|---------------------------------|-------------------------|---------------------------------|
| | HAMMOND POWER SOLUTIONS | | | | | | | | |
| | MELEDO (VI) - ITALY | | | | | | | | |
| THREE-PHASE REACTOR | | | | | | | | | |
| UNI EN ISO 9001 | | | | | | | | | |
| Code | <input type="text"/> | Serial N° | <input type="text"/> | Year 2014 | | | | | |
| L | <input type="text" value="mH"/> | I_{nom} | <input type="text" value="A"/> | I_{sat} | <input type="text" value="A"/> | f | <input type="text" value="Hz"/> | IP | <input type="text" value="00"/> |
| Class | <input type="text"/> | ΔT | <input type="text" value="°C"/> | Cooling | <input type="text" value="AN"/> | Weight | <input type="text" value="Kg"/> | V_{ins.} | <input type="text" value="KV"/> |
| NOTE | <input type="text"/> | | | | | | | | |

B - Steel label for reactors and reactor with steel enclosure

| | | | | | |
|-----------------------------|---------------------------------------|---------------------|--|----|-----------------|
| | Hammond Power Solutions | | HEAD OFFICE EUROPE via A. Schiatti, 12 36040 Meledo di Sarego (VI) - ITALY - tel. +39 0444 822000 www.hpseurope.eu | | UNI EN ISO 9001 |
| | REACTANCE | | | | |
| YEAR | <input type="text" value="2014"/> | CODE | <input type="text" value="WSMRTA01120"/> | | |
| PHASE N° | <input type="text" value="3"/> | SERIAL NUMBER | <input type="text"/> | | |
| FREQUENCY | <input type="text" value="50"/> Hz | INDUCTANCE | <input type="text" value="1.032"/> | mH | |
| COOLING | <input type="text" value="AN"/> | NOMINAL CURRENT | <input type="text" value="481"/> | A | |
| WEIGHT | <input type="text"/> kg | SATURATION CURRENT | <input type="text" value="-"/> | A | |
| PROTECTION DEGREE | <input type="text" value="IP23"/> | DIELECTRIC STRENGTH | <input type="text" value="20kV"/> | | |
| REACTANCE TYPE | <input type="text" value="DRY TYPE"/> | INSULATION CLASS | <input type="text" value="F"/> | | |
| | | OVERTEMPERATURE | <input type="text" value="100"/> | °C | |
| | | AMBIENT TEMPERATURE | <input type="text" value="40"/> | °C | |
| CURRENT AS TO LIMIT : 45 kA | | | <input type="text" value="1493659"/> | | |
| LIMITED CURRENT : 10 kA | | | <input type="text"/> | | |

3.1 - Check the condition for correct operation of the reactor

Before the installation of the reactor check the nameplate for the values below on the label:

- Connection of the terminals
- Ambient temperature where the reactor is installed and design for indoor or outdoor
- Rated level of insulation
- Rated inductance
- Rated current
- Notes

4 - RECEIVING, STORAGE AND TRANSPORT

4.1 - Inspection and acceptance

It is very important that you thoroughly inspect each unit prior to its acceptance and removal from the carrier's vehicle.

| | |
|---|---|
| For your convenience, below is a representative checklist area which should be checked prior to acceptance from the freight carrier: | |
| Is there any damage to enclosure parts like packaging or metallic box (if applicable) | |
| <input type="checkbox"/> Does the nameplate serial number agree with the packing list and Bill of Lading identification? | <input type="checkbox"/> Does the unit show any damage due to mishandling? Check for bars, connections, broken insulators, cracks in the windings, dirt or humidity, protective enclosure damage, foreign objects between the windings, etc. |
| Are the accessories damaged in any way? | |
| <input type="checkbox"/> Winding temperature indicator (if applicable) | <input type="checkbox"/> Fan motors and blades (if applicable) |
| <input type="checkbox"/> Pedestal (if provided) | |

If damage is detected or shortages are noticed, write a brief description on the Bill of lading and contact HPS S.p.A. with a telefax or by registered mail within the time declared in the conditions of supply from receipt of the reactor

4.2 - Lifting the reactor

All the HPS S.p.A. reactors must be lifted only by the method shown below:

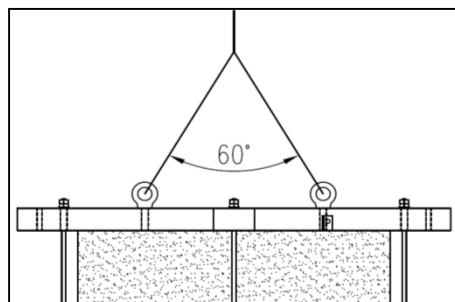

| |
|---|
| WARNING |
| Use all the eye bolts or lifting holes available in the upper side of the reactor |
| Do not allow the angle between the lift cables to exceed 60 degrees |

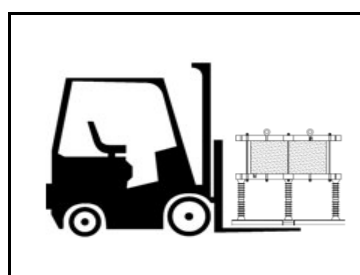

| |
|--|
| WARNING |
| Handle the reactor only in upright position |
| Care during lifting to prevent tipping over of the reactor |

4.3 - Moving the reactor with box (only if wheels provided)

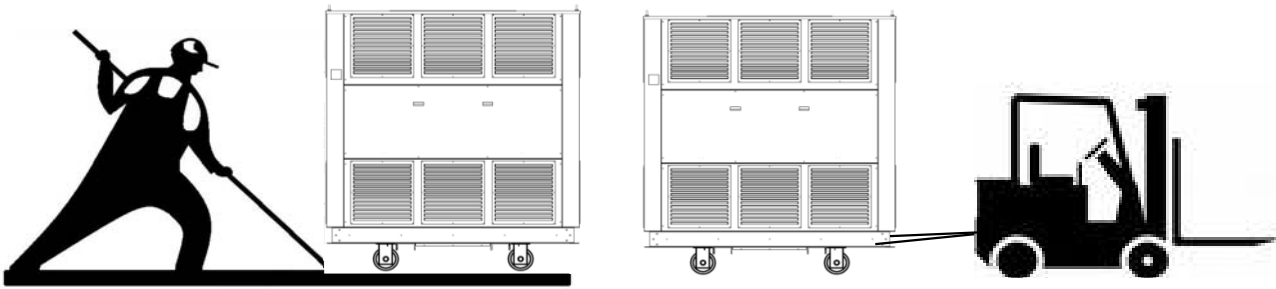

Move the reactor, whether alone or enclosed in an integral sheet metal box, by leverage against lower clamps or by means of its towing holes only

The unit can move in two directions only, depending on how the rollers are oriented

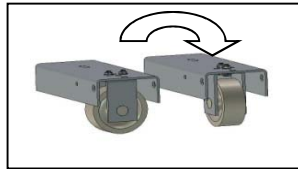

Never try to move the reactor by pushing or pulling on the windings

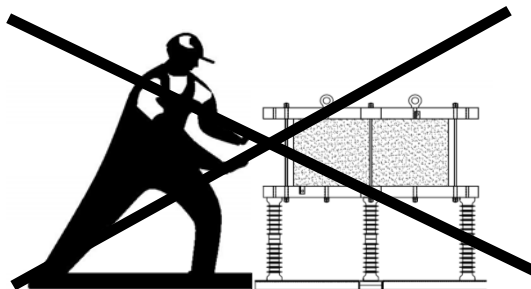

4.4 - Storage

If not installed immediately the reactors must be kept in the original packaging

Characteristic of the storage place:

- Free from metallic particles and corrosive gasses and vapors
- Dry to prevent moisture
- Free from dust and dirt
- Flat surface
- Temperature should not be lower than -25°C .



5 - INSTALLATION

Characteristic of installation place:

- Clean and flat surface.
- Clean and dry air free from dust.
- Without any risk due to the presence of flammable or explosive substances.
- Free from corrosive gasses, vapors and moisture.
- Max altitude: 1000 m
- No metallic part near the reactors must be create closed loops.
- Distances between the reactors to metal parts, building's metallic structure or concrete floor with reinforced metallic bars

The standards require that the reactors be accesible for inspection and located accordingly. However, reactors should not be located in areas where stored items are likely to interfere with either natural air convection or the capability to have them inspected. Passage ways or other areas where people could be exposed to live parts during inspection should also be avoided. Air core reactors can't be located outdoor without enclousure.

5.1 - Installation guide

The following picture offer an example of upper connections

The connecting cable or busbar must be:

- always fixed in a solid structure to not have mechanical forces on the reactor connections
- the distances shown in the table below:

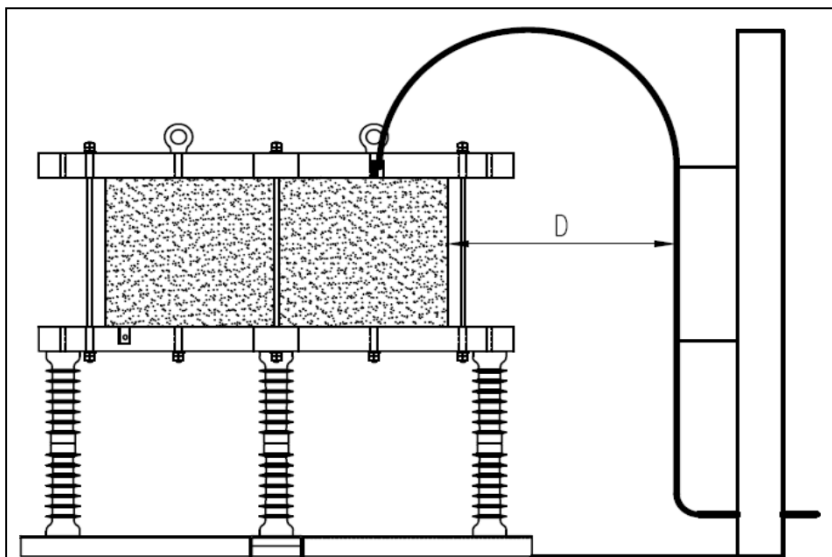

| kV | D (mm) |
|-------|--------|
| ≤ 1,2 | ≥ 25 |
| ≤ 2,5 | ≥ 50 |
| ≤ 5 | ≥ 100 |
| ≤ 8,7 | ≥ 130 |
| ≤ 15 | ≥ 200 |
| ≤ 18 | ≥ 250 |
| ≤ 24 | ≥ 300 |

5.2 - Connections

All connections should be made without placing undue stress on terminals. Connectors should be securely fastened in place and adequately supported with allowances for expansion and contraction.

Connection with cables

The cable connection should be done with tinned-copper cable terminals. For high current connect one or more cables per hole

The bolts used for connection are usually brass bolt directly connected to the end of winding

Do not replace the brass bolts with bolts of a different material: it could alter the connection

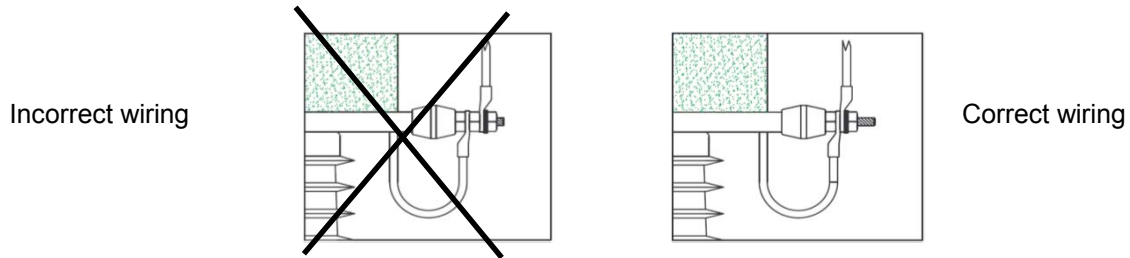

Connection with busbar

When connecting the aluminium bars to copper bars, causing a direct connection between copper and aluminium, it is necessary to use CUPAL intermediate plates

HPS S.p.A. air core reactor can be designed with many types of connections depending on the current value and the customer requests.

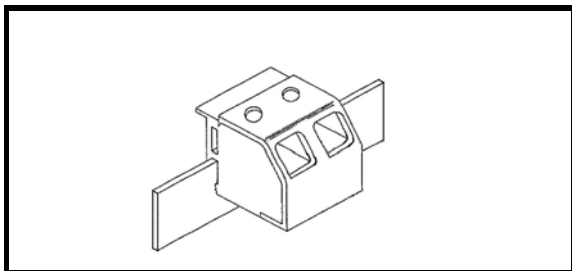

Low current clamps

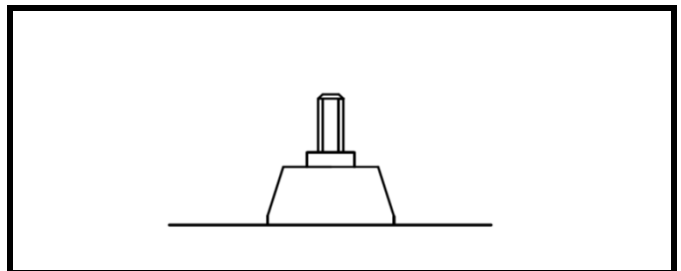

High current clamps

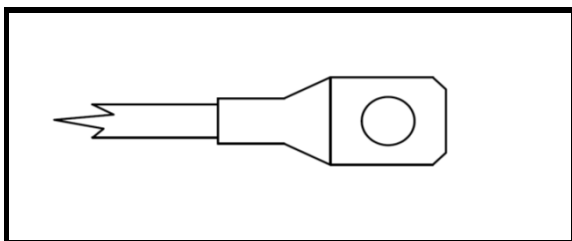

Lug connection

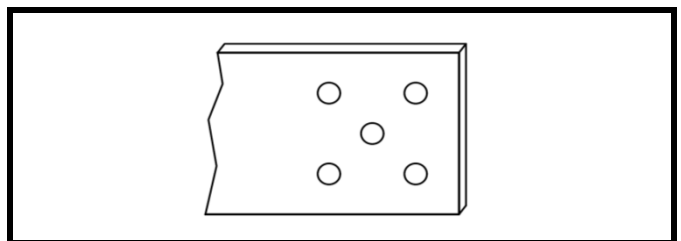

Busbar connection

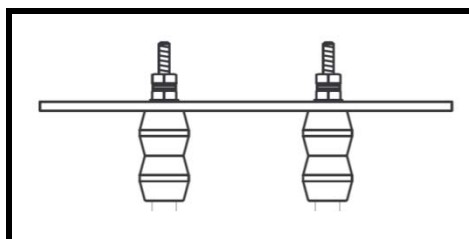



Bolted connection

5.3 - Tightening torque for electrical and mechanical connections

Block and/or tighten both the electric and mechanical connections in accordance with following values

When making cable connections or changing taps, always use two wrenches for tightening or loosening bolted connections to prevent distortion or damage.

|  | Electrical connection | | Mechanical connection |  |
|---|-----------------------|---------|-----------------------|---|
| | [Nm] | | [Nm] | |
| Screw / Bolt | Steel | Brass | | |
| M 6 | 10 - 15 | 5 - 10 | 20 | 10 |
| M 8 | 30 - 40 | 10 - 15 | 35 | 13 |
| M 10 | 50 - 60 | 20 - 30 | 45 | 17 |
| M 12 | 60 - 70 | 40 - 50 | 60 | 19 |
| M 14 | 90 - 100 | 60 - 70 | 100 | 22 |
| M 16 | 120 - 130 | 80 - 90 | 150 | 24 |
| M 18 | - | - | 200 | 27 |
| M 20 | - | - | 270 | 30 |
| M 22 | - | - | 360 | 32 |
| M 24 | - | - | 460 | 36 |

5.4 - Positioning



The IP00 reactors do not assure contact insulation
It is absolutely forbidden to touch the coils while the transformer is energized

Each specific reactor design will specify magnetic clearance requirements.

The minimum magnetic clearances to metallic parts and between reactor coils must be maintained to avoid excessive heating effects in steel reinforced, concrete foundations, surrounding fences or steel structures in the vicinity of the reactors.

It is important, even outside these minimum magnetic clearances, to avoid closed electrical loops which could lead to high circulating currents within the loop.

The value shown are only guidelines.

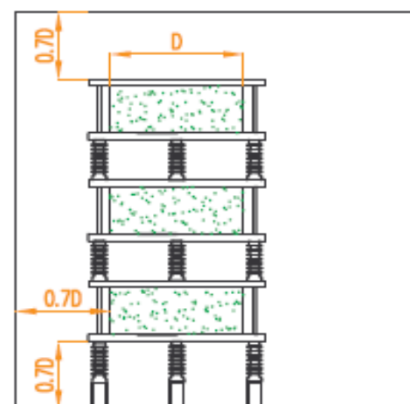
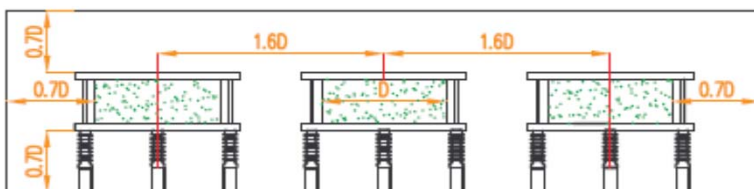

Distance between a wall to the air-reactor with enclosure

- For ventilation: the correct air flow on the enclosure must be guaranteed (see 5.5)
- For accessibility: the space to disassemble a lateral panel of enclosure must be guaranteed

5.5 - Ventilation

Dry-type general-purpose air reactors are cooled by free circulation of surrounding air. The air has to enter at the bottom, flow upward over the coil surfaces and exit through the openings near the top.

The reactors will carry full-rated current continuously when the surrounding air does not exceed what is written on the label

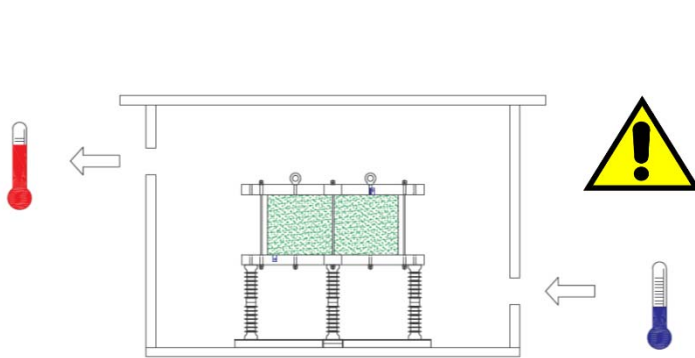

Characteristic of cooling air

- Dry
- Clean
- Free from dust
- Free from acid vapor and gasses
- Free from metallic particles

As air should flow on cooling surfaces, inlet and exhaust openings should be correctly dimensioned. Should the air flow be inadequate, the reactor would experience anomalous heating, which could cause the thermal protection system to trip

5.6 - Dry out

If an indoor type reactor has been exposed to moisture such as condensation or rain, or stored in a high humidity environment, the unit must be dried out prior to energization.

1- Remove immediately the reactors from service

2- Proceed with any of the following dry-out methods:



- Free moisture should be blown or wiped off any surface of the reactor to reduce the time of the dry-out period.
- Direct external forced air, hot or warmed, or radiant heat up through the windings with all the ventilation openings cleared. Recommended temperature should not exceed 80°C. Continue this for 24 hours or until all evidence of moisture or condensation is no longer visible.
- Dry-out with internal heating **SHOULD NOT** be permitted

5.7 - Overvoltages

In the case that the reactor is exposed to over-voltages (due to atmospheric events, the operation of circuit breakers or other causes) appropriate surge arrestors set, fuses or circuit breakers for the insulation level are necessary



6 - COMMISSIONING

Final activities and inspection prior to energization

6.1 - Earth Connection

All noncurrent carrying metal parts in reactors must be grounded, including the enclosure.



Care should be taken that grounding will not be forming close loops.



6.2 - Cleaning

If the reactor has been stored for a long period, clean it thoroughly. The windings may be cleaned with a vacuum cleaner, blower, or with compressed air. The a vacuum cleaner is preferred as first step to avoid dispersion of dirt and dust on the transformer. Do not use liquid cleaners.

6.3 - Electrical inspection check list



- All external connections have been made properly.
- All connections are tight and secure.
- All accessory circuits are operational.
- All tap connections are properly positioned.
- The ground connections have been properly made.
- Fans (if supplied) are operational.
- Proper clearance is maintained from bus to terminal equipment.
- All windings are free from un-intended grounds.

6.4 - Mechanical inspection check list



- There is no dust, dirt or foreign material on the coils.
- There is no visible moisture on or inside the coils or enclosure.
- All plastic wrappings are removed from the coils.
- All shipping members have been removed.
- There are no obstructions in or near the openings for ventilation.

7 - MAINTENANCE

Under normal operating conditions and environments, HPS S.p.A. reactors do not required maintenance.

However, periodic care and inspection is a good practice, particularly if the unit is exposed to extreme environmental conditions.

7.1 - Suggested maintenance and control activities

| <i>Item</i> | <i>CONTROL</i> | <i>FREQUENCY</i> | <i>INSTRUMENT TO BE USED</i> | <i>ACTIVITY</i> |
|-------------|--|---|---|---|
| 1 | Function of the temperature sensors. PT100 / PTC | Yearly / when needed | Tester | Electrical continuity |
| 2 | Monitoring device | Monthly / after exceptional events | - | Function check according to manufacturers instructions |
| 3 | Cleaning of dust, dirt, possible foreign materials on the windings | Every 6 months / when the reactor is de-energized | Clean, dry compressed air, max pressure 3 bar. Dry wiping rags | The ventilation gaps between the windings must be completely clean and open |
| 4 | Moisture on the windings | After a period not in use with no applied voltage | Oven / method of heating in short circuit | Drying at 80°C |
| 5 | Tightening of the bolts for electrical connections | Yearly / when needed | Torque wrench | Tightening torque according to paragraph 5.3 |
| 6 | Insulation between windings and earth | After a period not in use with no applied voltage | Mega-ohmmeter (Megger) with voltage more than 1000 V | Coil-Ground: min 2 Mohm per 1000 volts of nameplate voltage rating, but in no case less than 2 Mohm. Should the value be lower, contact HPS S.p.A. |
| 7 | Applied-voltage test in the field | After exceptional events (shock or a short circuit, etc.) | Appropriate instrumentation | Where test are conducted in the field the test voltages shall not exceed 75% of factory test values |

7.2 - Guide for trouble-shooting

| <i>SYMPTOM</i> | <i>CAUSES</i> | <i>CHECKINGS AND ACTIONS</i> | |
|---|---|---|--|
| <i>Electric circuit</i> | | | |
| Windings overheating | Continuous overload; wrong external connections; poor ventilation; high air temperature; damaged or improperly directed fan blades; high harmonic or unbalanced loads. | Rated characteristic Ventilation Reactor connection | See 3.1 See 5.5 See 5.2 - 5.3 |
| Reduced or zero current | Loose electrical connections | Reactor connection | See 5.2 - 5.3 |
| Insulation failure | Continuous overcurrent; dirty accumulations on coils; mechanical damage in handling; lighting or switching surges. | Rated characteristic Cleaning Handly Overvoltage | See 3.1 See 7.1 See 4.2 - 4.3 See 5.7 |
| Breakers or fuses opening | Breaker or fuse with no delayed opening; short circuits; overcurrent | Rated characteristic Protection device | See 3.1 See 5.6 |
| Excessive cable heating | Improperly bolted connection; incorrect cable size for load; incorrect cable routing. | Reactor connection Ventilation | See 5.2 - 5.3 See 5.5 |
| Vibration and noise | High frequency of current; windings clamps loosened in shipment/handling; installation on suspended floors or close to reflective wall; connection with no flexible conductors | Rated characteristic Mechanical connection | See 3.1 See 5.3 |
| Over-heating of the metal structures near the reactor | Incorrect distances between the air core reactors without enclosure to a buliding's metallic structure or on a concrete floor with reinforced metallics bars. Presence of closed loops on adjacent metallic part. | Rated characteristic Maintenance | See 3.1 See 7.1 |
| <i>Dielectric materials</i> | | | |
| Smoke | Excessive varnish could burning clear on first start-up that may cause smoke. This is not a problem for the transformer but if the smoke don't stop, an insulation failure could be occurs. | Installation Positioning | See 5 See 5.4 |
| Burned insulation | Lighting surge; switching/line disturbance; excess dirt or dust on coils. | Overvoltage Maintenance | See 5.7 See 7.1 |
| Overheating | Clogged air dust or inadequate ventilation. | Ventilation | See 5.5 |

7.3 - Customer Care

For more information or spare parts do not hesitate to contact our customer service.
Call +39 0444 822000 or send an e-mail to: info@hpseurope.eu

Do not forget the registration number of your reactor.

7.4 - Warranty

HPS S.p.A. makes no warranties, express or implied, whether of merchantability, fitness for a particular purpose, performance otherwise, except as follows.

HPS S.p.A. obligation under this warranty shall be limited to repair or replacement of parts proven within the warranty period to have been defective at time of shipment.

Upon discovery of any such defects, purchaser shall promptly notify HPS S.p.A. thereof and, if requested by HPS S.p.A. return the defective parts to HPS S.p.A..

Purchaser shall be responsible for all expense of removal, freight and reinstallation in connection with repairs or replacement of defective parts.

In no event will HPS S.p.A. be responsible for or reimburse purchaser for repairs or replacements made by others. In no event and under no circumstances shall HPS S.p.A. be liable for loss of anticipated profits or for interruption of operations for any special, incidental or consequential damages whatsoever

**CONSULT FACTORY FOR SPECIAL CONDITION AND
APPLICATIONS**

HAMMOND POWER SOLUTIONS S.p.A.

Via A.Schiatti, 12
36040 Meledo di Sarego (VI) Italy
tel: +39 0444 822000
fax: +39 0444 822010
www.hpseurope.eu

Technical department e-mail: info@hpseurope.eu